

Embassy gardens

Blocks **B, H, & J**
(Rented)

**APARTMENT SERVICES
QUICK STEP GUIDE
USER MANUAL**



CONTENTS

1. Operate Your Heating & Hot Water	4
1.1 Description of System	4
1.2 User Quick Setup Guide	7
• Setting the Time & Date	7
• How to Turn Your Heating ON / OFF	8
• How to Programme Your Heating Schedule(s)	9
• Set AUTO Mode	10
1.3 HIU Unit Settings	11
• System Settings	11
• System Information	13
• Temperature Setting	14
• Selecting an Operating Mode	16
• Time Schedule Programming	18
• Set AUTO Mode	19
1.4 HIU Unit Checks	20
• Check the Pressure of Your System – When It Drops Below 1.5 Bar Pressure	20
• How to Increase the Pressure of Your HIU Unit	21
• Decreasing the Pressure of Your Unit	24
• Technical Support	25
2. Home Air Circulation Fan	26
2.1 Description of System	26
2.2 How the MVHR System Works	27
2.3 Filter and Routine Maintenance	28
• Filter Maintenance	28
• Routine Maintenance	29
• Technical Support	30
3. Your Apartment Lamps	31
3.1 Product Description	31
3.2 How to Change Your Lamp	32
3.3 Lamp Safety	35

4. Door Entry Phone	36
4.1 COMELIT ICONA DOOR ENTRY PHONE	36
4.2 DOOR ENTRY MONITOR FUNCTIONS	40
• INTERCOMS	41
• CAMERAS.....	41
• OPEN DOORS	42
• ANSWERING SERVICE SETUP.....	42
• MESSAGES	43
• CALL DIVERT	44
• VIDEO MEMORY	44
• AUDIO MESSAGE	44
• MULTIPLE ADDRESSES.....	45
4.3 AUDIO BROADCAST	46
4.4 SETUP MENU	48
5. Shower Unit ALTO ECOTHERM (A5636)	55
5.1 Operation	55
5.2 Temperature Setting	56
5.3 Cleaning.....	57
5.4 Maintenance	58
6. RADIATORS & Towel Rad	60
7. FAQ	61
7.1 Operate your Heating.....	61
7.2 Home Air Circulation Fan	61

1. OPERATE YOUR HEATING & HOT WATER

Room Heating Controller – Evinox (ModuSat TP)

You can find information over the following pages about how to operate the ViewSmart Room Controller in your home.

1.1 [Description of System](#)

Home Screen & Buttons



Comfort mode

Home screen information shown clockwise

1. Day and Time

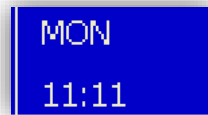

2. Current Room Temperature

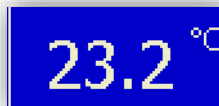

3. Current Mode





4. Alarms (Any Alarms Will be Shown Here and the Red LED Light will be ON.)



-

Key to Symbols

The following symbols are displayed in the bottom left hand corner of the home screen and indicate the current system status –

-  Circle Symbol - System Idle
-  Radiator Symbol - System in Heating Production
-  Tap Symbol- System in Hot Water Production

The following symbols are displayed next to the date and time on the home screen –

-  Clock Symbol - This will be displayed when a Time Schedule is activated
-  Holiday symbol - This will be displayed when a Holiday Schedule is activated

Description of Operating Modes

Comfort (ON)

Comfort mode should be set to the room temperature required when the home is occupied. (Recommended temperature set point is 21°C)

ECO

ECO mode should be set to the minimum room temperature required when the home is not occupied. (Recommended temperature set point is 15°C)

DHW Comfort (Domestic Hot Water)

Domestic Hot Water (DHW) Comfort mode ensures that the hot water plate heat exchanger within your ModuSat heat interface unit remains at a set temperature to optimise the production of your hot water. The Comfort temperature is factory pre-set at 55°C and we recommend you do not adjust this setpoint. (DHW Comfort mode ensures instantaneous hot water delivery)

DHW ECO (Domestic Hot Water)

Domestic Hot Water (DHW) ECO mode can be set to a lower temperature than the DHW Comfort mode for periods when the home is unoccupied. We recommend that the ECO temperature is set at 25°C for apartments and 20°C for houses. (DHW ECO mode uses less energy but there will be a slight delay in hot water delivery to the tap)

Anti-freeze (Frost)

Anti-freeze (Frost) is factory set at 10°C. This mode should be selected to provide frost protection when the property is unoccupied for long periods. (Note: Anti-freeze (Frost) disables the heating mode unless the temperature falls below the set 10°C)

OFF

This mode turns off the Heating & Hot Water. (Please be advised when OFF mode is selected this provides no protection against frost)

AUTO

The Auto mode must be applied to activate any Time Schedules that have been created. (See Time Schedule Programming Page 9 for further information)

Quick-set the heating from the Home Screen

From the Home screen you can use the Plus & Minus buttons to increase or decrease the required room temperature. If you increase the temperature above the current room temperature this will activate the heating. If you decrease the temperature below the current room temperature and the heating is on it will be turned off. (Not applicable when the unit is in OFF mode)

1.2 [User Quick Setup Guide](#)

Time & Date

- **Setting the Time & Date**
 1. Press the **Home** button to view the Main Menu.
 2. Select **SYSTEM** by scrolling down using the – **button** and pressing the **Right Hand Scroll** button to enter the menu.
 3. Select **DATE/TIME** using the **Right Hand Scroll** button to enter the next screen.
 4. Here is an example showing the **DATE /TIME** Screen, where you can make changes using the **Right Hand Scroll** button and the + & - **buttons**.
 5. Press The **ENTER BUTTON**, while each value is highlighted, to save each change.

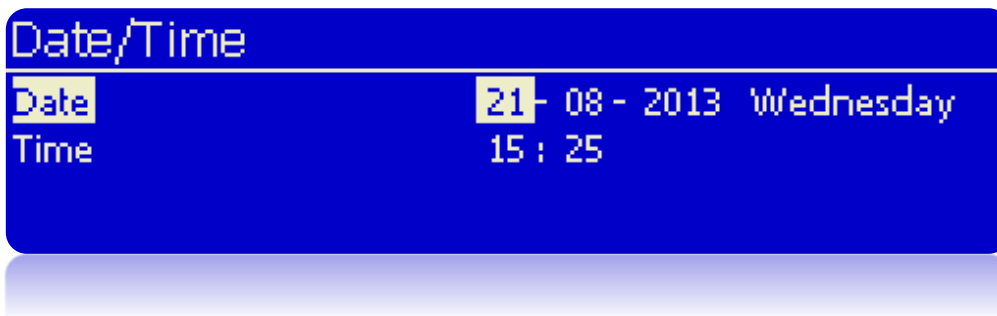

- How to Turn Your Heating ON / OFF

1. From the Home screen you can use the **Plus & Minus** buttons to increase or decrease the required room temperature.
2. **To turn the heating ON** – Press the **+** **button** to increase the temperature above the current room temperature this will activate the heating.



3. The Radiator symbol will be displayed when the heating is on –
4. **To turn the heating OFF** - Press the **- button** to decrease the temperature below the current room temperature and the heating will be turned off.



5. The System Idle symbol will be displayed when the heating has been turned off –
(You do not need to press the Enter button to save changes).

- How to Programme Your Heating Schedule(s)

(The controller can be set to programme the heating for weekly, daily and weekend schedules.)

1. Press the **HOME** button to view the Main Menu.
2. Select **SCHEDULES** by scrolling down using the **- button** and pressing the **Right Hand Scroll** button to enter the menu.
3. Scroll down using the **- button** and select **HEATING**. Press the **Right Hand Scroll** Button to enter the next screen.
4. Use the **Right Hand Scroll** Button to highlight the values and the **+ & - Buttons** to scroll through the Days, Times and Modes
5. For heating ON Select COMFORT mode.





(The example shows a schedule for the Heating to be switched ON Mon - Fri between 7am-9am)

6. Press the **ENTER** button, while each value is highlighted, to save each change.
7. Set to **Auto Mode**. You must select the **AUTO** operating mode, as per the instructions below, to activate the time schedule programme.

- Set AUTO Mode

1. Press the **HOME** button to view the Main Menu.
2. Select **USER SETTINGS** using the **Right Hand Scroll** Button.
3. Select **MODE** by scrolling down using the **- button** and press the **Right Hand Scroll** button to enter the Mode menu.
4. Select **HEATING MODE** using the **Right Hand Scroll** and then the **+ and - buttons** to scroll through to **AUTO**.
5. Press the **ENTER** button, while the mode is highlighted, to save the change.

1.3 HIU Unit Settings

- System Settings

(Here you can view general system settings such as the date and time, language and system information.)



1. From the Home Screen - Press the Home button to view the Main Menu.

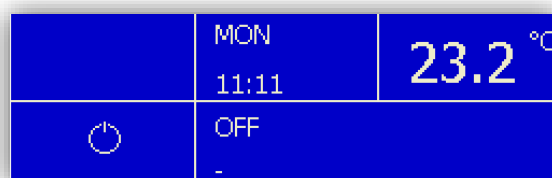

2. Scroll down using the - button and select "System" using the Right Hand Scroll button.



3. Scroll up and down using the + & - buttons and select the required item using the Right Hand Scroll Button to enter the next screen.

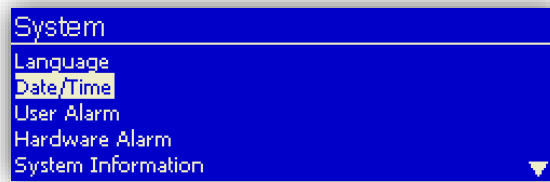

4. Here is an example showing the Date / Time Screen, where you can make changes using the Right Hand Scroll button and the + & - buttons. **Press the Enter button, while each value is highlighted, to save each change.**

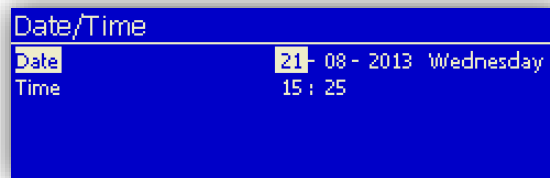

- System Information

(Here you can view information about the heating and hot water system.)



1. From the Home Screen - Press the **Enter** button to view the “System Information” screen.

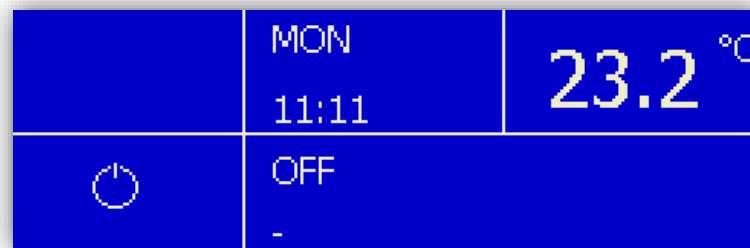

2. Scroll up and down using the + & - buttons to view the system information.

System Information	
Primary Circuit Supply Temperature	-10.0 °C
Primary Circ Return Temperature	-10.0 °C
Primary Flow Rate	0 m3/h
DHW Supply Temperature	25.0 °C
DHW Valve Position	0 % ▼

- Temperature Setting

(This operation allows the user to set the temperature set point for Comfort, ECO, Anti-freeze, OFF, KWF Comfort and KWF ECO, which can follow the daily or weekly set time schedule, or be set to run 24/7..)



1. From the Home Screen - Press the Home button to view the Main Menu.

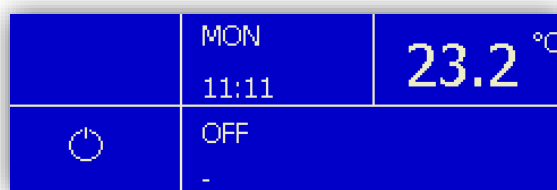

2. Select "User Settings" using the Right Hand Scroll Button.



3. Select "Set points" using the Right Hand Scroll Button.

Please note: Summer\Winter Switch Over is only applicable to Heating & Cooling models.

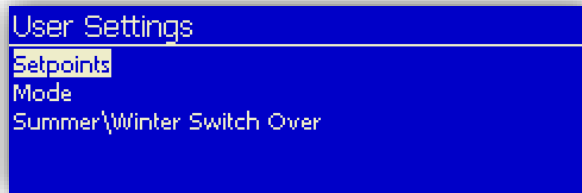

4. Use the + & - Buttons to scroll up and down the menu and select the Mode you wish to adjust. Use the Right Hand Scroll button to highlight the temperature and the + & - Arrows to increase or decrease the temperature setting.

Press the Enter button, while the temperature is highlighted, to save the change.

Press the Home button to return to the Home screen.

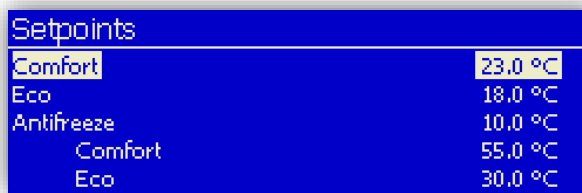

- Selecting an Operating Mode

(This operation allows the user to set the operating mode for the Heating & Hot Water: Comfort, OFF, Antifreeze, ECO, Auto, KWF Comfort and KWF ECO.)



1. From the Home Screen - Press the Home button to view the Main Menu.

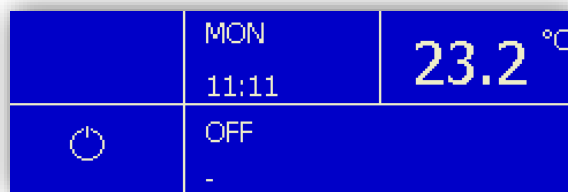

2. Select "User Settings" using the Right Hand Scroll Button.



3. Select "Mode" by scrolling down using the – button and press the Right Hand Scroll button to enter the Mode menu.

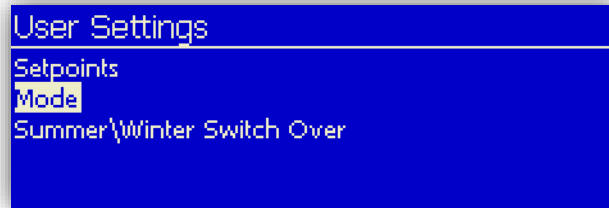

4. Here you can change the Mode for the Heating or Hot Water by using the Right Hand Scroll and then the + and – buttons to scroll through to the desired mode. (Note: when Comfort mode is selected the system runs 24/7 as per the setpoints). **Press the Enter button, while the mode is highlighted, to save the change.** Press the Home button to return to the Home screen.

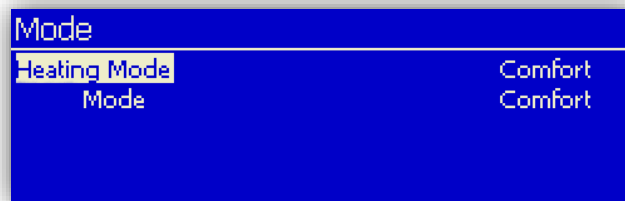

- Time Schedule Programming

(The time schedule can be set to control the Comfort, Antifreeze, ECO, OFF, Auto, KWF Comfort and KWF ECO operation of the system. Weekly, daily and weekend schedules can be set.)



1. From the Home Screen - Press the Home button to view the Main Menu.

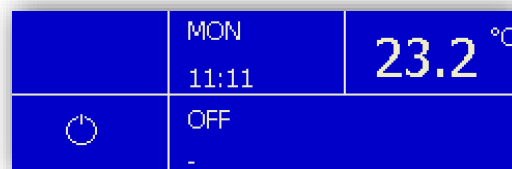

2. Select "Schedules" by scrolling down using the – button and pressing the Right Hand Scroll button to enter the menu.



3. Scroll using the + & - buttons and select the required Schedule (Heating, DHW or Holiday).

Press the Right Hand Scroll Button to enter the next screen.

(Please note: When a Holiday Schedule is activated this automatically overrides the Heating & Hot Water Time Schedules).

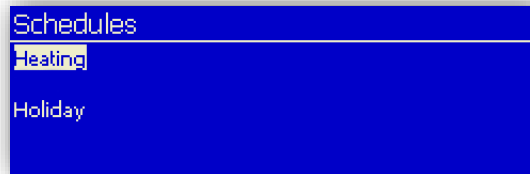

4. Here you can create a schedule. Use the Right Hand Scroll Button to highlight the values and the + & - Buttons to scroll through the Days, Times and Modes. (The example above shows a schedule for the Heating to operate in Comfort Mode Mon - Fri between 7am-9am)

Press the Enter button, while each value is highlighted, to save each change. Press the Home button to return to the Home screen.

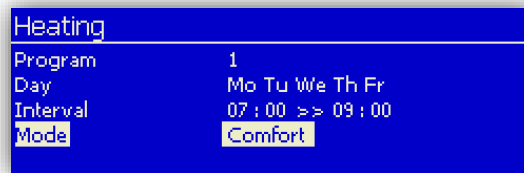

8. Set to **Auto Mode**. You must select the **AUTO** operating mode, as per the instructions below, in **"Selecting Operating Modes"**, to activate the time schedule programme. (For example, if you have selected a Time Schedule Programme for your heating you must select **"AUTO"** mode for the Heating in the **"Mode"** screen).

- Set AUTO Mode

1. Press the **HOME** button to view the Main Menu.
2. Select **USER SETTINGS** using the **Right Hand Scroll** Button.
3. Select **MODE** by scrolling down using the **- button** and press the **Right Hand Scroll** button to enter the Mode menu.
4. Select **HEATING MODE** using the **Right Hand Scroll** and then the **+ and - buttons** to scroll through to **AUTO**.
5. Press the **ENTER** button, while the mode is highlighted, to save the change.

1.4 HIU Unit Checks

- Check the Pressure of Your System – When It Drops Below 1.5 Bar Pressure

In order to maintain the correct working pressure within your HIU Unit, the home owner should check the reading on the Pressure Gauge dial (manometer) displayed on the unit. Failure to maintain this correct idling and working pressure could result in your HIU Unit not performing to its manufacturing standards and could cause permanent damage to the Unit.

This Pressure Gauge dial is located within your apartments HIU cupboard and located to the front of the HIU Unit. (Please see figure 1.1).

- The correct system gauge idling pressure reading when cool, should be between 1bar and 1.5bar.
- The correct system gauge working position when the system is Hot, should be maintained between 1.5bar 2 bar.



Figure 1.1 (HIU Pressure Gauge - manometer)

- How to Increase the Pressure of Your HIU Unit

Your HIU unit should be set to the limits as listed below to achieve its optimum working pressure:

- When the heating system is cool, the pressure should be between 1 and 1.5 bar on the pressure gauge.
- If pressure is below 0.5 bar, water has been lost from the system and must be replaced. (Note: The gauge could also indicate the pressure being too high - approximately 2.5 bar or more).
- If the pressure gauge indicates high pressure as a result of over filling, you will need to bleed a radiator until the pressure gauge returns between 1 and 1.5 bar. (Please see section on: *Decreasing the Pressure of Your Unit*).

If the pressure (bar) values go below the optimum working pressure you can increase the pressure of the system by use of a bypass loop, connected at the top of the HIU unit.

Procedure:

Please carry out the following steps only if you are competent and trained to do so:

- Step 1. Please ensure you use the correct PPE (Personal protective equipment):
 - Safety glasses
 - Appropriate hot works gloves
 - Additional safety equipment where applicable
- Step 2. Please use a safe raised working platform and do not stand, kneel or ever use the HIU cupboards shelf as a working platform.
- Step 3. Above the HIU unit there is a Valve Kit installed (Please see figure 1.2). There are multiple Valves present. Locate the valves and make sure the valves are in their closed position, i.e. in their anticlockwise position.
- Step 4. Remove the caps A and B by unscrewing them counter clockwise (Please see figures 1.3 & 1.4).



Figure 1.2 - View above HIU unit, the closed valves with caps (A) and (B)



Figure 1.3 Turn the cap anticlockwise to loosen it and remove. Figure 1.4 The pipe caps will get hanging from the valves

Step 5. Connect the filling loop provided, by screwing both ends onto valves (A) and (B), in a clockwise rotation.



Figure 1.5 Screwing clockwise the first end pipe



Figure 1.6 Screwing the second end pipe

Step 6. When you have fitted the filling loop and it has been fixed into position, it should resemble the picture below.



Figure 1.7 - View above HIU unit, with filling loop connected

Step 7. Once you have the filling loop pipe connected:

- You open the right-hand valve first.
- Then once you have the valve in its fully open position, you begin to open the left-hand side valve in a slow anticlockwise motion.
- You will hear water begin to fill in through the pipe (filling loop) and into the HIU system.
- You will need to keep a close watch on the pressure indicator (bar gauge) as the pressure begins to rise (Please see figure below).
- When the pressure reaches 1.5bar, close the left and right valves simultaneously. Unscrew the filling loop and return the valve caps to their original position. Store the filling loop safely into its original position for ease of use if required again in the future.

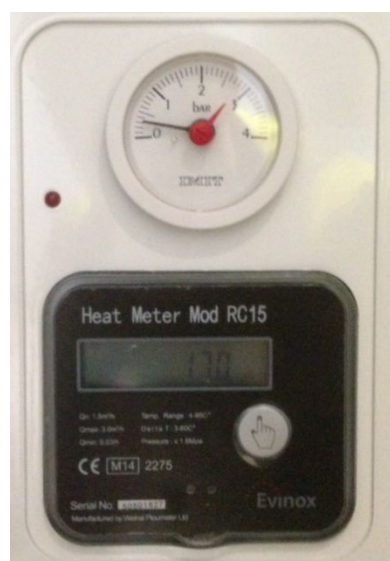

Figure 1.8 – Front view of HIU, with low pressure registered (<1.5 bar)

- Decreasing the Pressure of Your Unit

If pressure rises by more than 1 bar when the heating is up to temperature, then the expansion vessel may require re-pressurizing. This will require a service engineer. The pressure in the system will usually require topping up once or twice a year. If you are having to re-pressurize your heating system much more frequently, please contact your installer.

- Step 1. In order to get your unit at the optimum pressure, you can decrease the pressure of the HIU system by removing some water/air from the systems radiator.
- Step 2. You need to position a bucket below the valve of the radiator (Note: Please use a suitable cloth for any unexpected spillages).
- Step 3. Position the bucket under the valve where the pressure valve key is positioned.
- Step 4. Using the pressure release radiator key, slowly turn the key anticlockwise to release the water into the bucket, until you see the water flowing and the air being released (Please see figures 1.9 & 1.10 below)
- Step 5. You will then need to carefully control the flow of the water by turning the radiator key, which will in-turn release the pressure from the HIU unit.
- Step 6. When the pressure is at its optimum cold idling pressure level (1.5 bar), you can turn the radiator key in a clockwise rotation until the valve closes, which will end the process.



Figure 1.9 Pressure release Radiator key in position



Figure 1.10 Key turning anticlockwise to release the water

- Technical Support

Contact details

For more information on how to operate your Heating and Hot Water please call technical support on:

01372 722 277

2. HOME AIR CIRCULATION FAN

2.1 [Description of System](#)

Note: It is strongly recommended to read the FAQ for this chapter.

Your apartment is equipped with a Vent-Axia MVHR Ventilation System. The MVHR Fan is located in the Utility Cupboard, it's comprised of air extraction points in the Kitchen and bathrooms, and air supply points in Bedrooms and Living Room.

You don't need to setup anything. MVHR Fan is working automatically.



MVHR Fans (Mechanical Ventilation with Heat Recovery):

1. Vent – Axia Sentinel Kinetic MVHR; whole house mechanical supply and extract ventilation unit c/w recover; Boost operated by integrated humidity sensor. For basic description, please read the FAQ.
2. Vent – Axia Sentinel High Flow; whole house mechanical supply and extract ventilation unit c/w recover; Boost operated by integrated humidity sensor

Note: These systems are heat recovery ventilation systems, **NOT AIR-CONDITIONING SYSTEM**. It offers the highest level of comfort and control available.

Note: The most common concern with home owners is that heat ventilation devices create noise. With Advance, absolute optimisation of every element does everything possible to minimise generation and transmission of both motor and airflow noise.

2.2 How the MVHR System Works

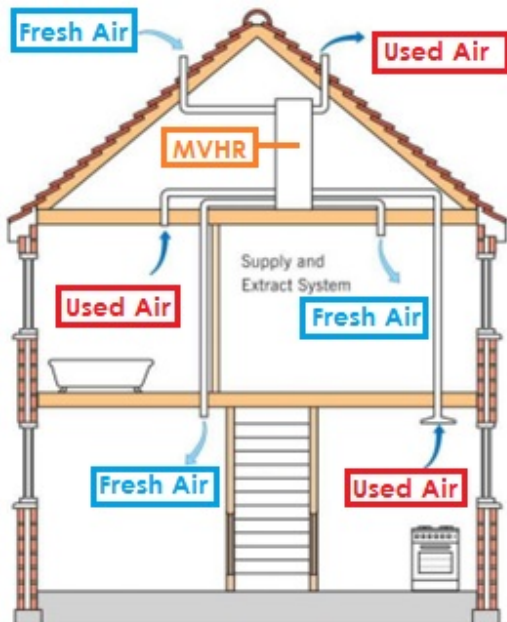

- ✓ MVHR supplies & extracts air continuously at a low rate with boost facility to extract pollutants and supply fresh outdoor air at a higher rate as required
- ✓ Can be controlled either; - Manually via single or multiple switches - Automatically, typically via humidity or other sensors These should be clearly marked and located in an accessible location in or near the wet rooms - Normally the MVHR unit is sited remotely in a loft space or cupboard and ducted via rigid duct to outside air using the most economical route
- ✓ Replacement tempered air is introduced into bedrooms and living areas by the system, therefore background ventilators in windows are not required

The Home Air Circulation Fan Unit moves air around your property at such a low level that you never feel it, but it takes all the stale air from inside your house and replaces it with clean fresh air, 24 hours a day, 7 days a week. Your home is ventilated without the need to open windows which can let in noise, fumes and can compromise security.

When the integrated humidity sensor detects a higher humidity than the one set up in the system, it will turn on the Boost extract fan in the bathroom area. The boost extract fan will remain on until the humidity has gone below the setpoint.

Important:

Unit must not be switched off, product is designed to run continuously.

2.3 Filter and Routine Maintenance

All ventilation units require periodic maintenance. Routine maintenance must only be carried out by a suitably qualified and competent person.

- Filter Maintenance

Filters should be cleaned when indicated by the unit control panel (“Check Filters”) at varying intervals depending on the external environment or every 6 months (recommended) if not indication is shown in the Unit.

1. Open front flaps and remove the filters.

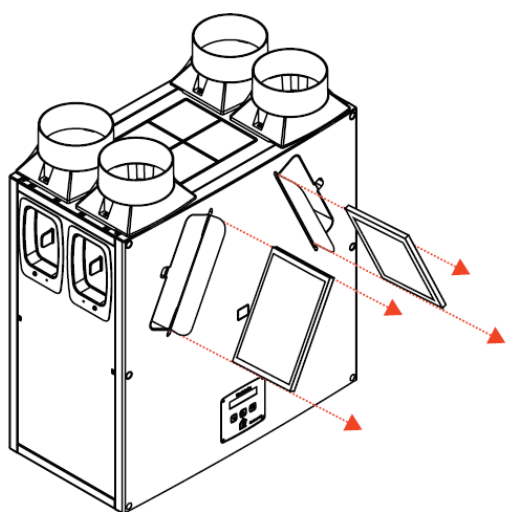

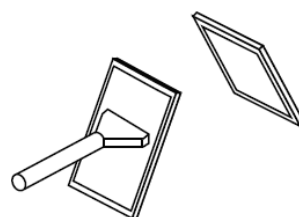

2. Gently vacuum the filters

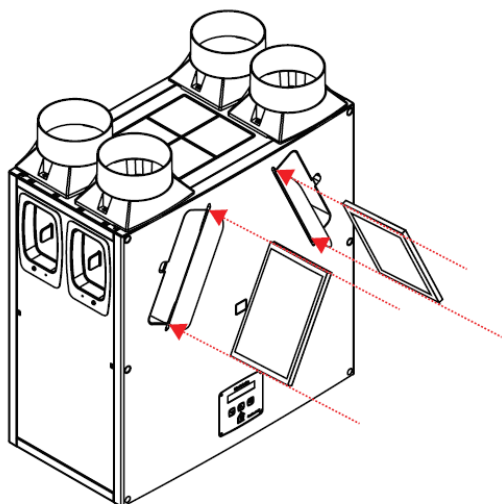

3. Replace in reverse order



4. Filters should be replaced every two years, or after three cleaning cycles. Contact Vent-Axia Sales by calling 0844 856 0590 quoting the model reference.

Once the filter is cleaned or replaced, the automatic message has to be reset. Press and hold the  and  buttons for 5 seconds.

The product should be professionally serviced every two years.

- **Routine Maintenance**

The Vent-Axia Kinetic Unit must be periodically maintained. It has been designed to facilitate access to enable maintenance to be carried out easily. The maximum time between cleaning will depend on the local environment. Vent-Axia recommends the unit be cleaned every 12 months.

In the event of any queries please contact the system installer. **WARNING:** The unit uses a 230V ~ supply and contains rotating mechanical parts. ISOLATE the unit from mains power supply and allow sufficient time for all moving parts to stop before undergoing any Servicing or Maintenance.

Cleaning Exterior

For best results use a clean cloth and warm water with a mild detergent solution. Do not use solvents or abrasive cleaners.

Cleaning Interior

For best results use a clean damp cloth and mild detergent. Do not use solvents or abrasive cleaners. When cleaning the interior ensure that the humidity sensor does not get wet, dust with a dry cloth.

Note: Routine maintenance must only be carried out by a suitably qualified and competent person.

Cleaning Procedure for Your Air Circulating Fan

- Step 1. Please use the correct PPE (Personal protective equipment):
 - i. Safety glasses
 - ii. Appropriate hot work gloves
- Step 2. Please use a safe raised working platform and do not stand, kneel or ever use the HIU cupboards shelf as a working platform.
- Step 3. Turn off isolator switch located in the fuse box prior to commencing work (Please see figure 2.1).



Fuse box (Figure 2.1)

- Step 4. Remove the Front Cover from the unit and remove the 2 filters (Take the opportunity to clean the filters at this time)
- Step 5. Slide out the Heat Exchanger.
- Step 6. Wash the outer cover and heat exchanger in warm water using a mild detergent and dry thoroughly.
NOTE: Keep water away from all electrical components and wiring within the unit.
- Step 7. Inspect the motors for build-up of dust and dirt on the impeller blades, which could cause imbalance and increased noise levels. Vacuum or clean if necessary.
- Step 8. Check the condensate drain tube is secure and clear of debris. Clean if necessary.
- Step 9. Check that all unit and wall-mount fastenings are sufficiently tight and have not become loose. Re-tighten if necessary.
- Step 10. Put back the filters and any other item back to their position and place the front cover back again. Turn on the isolator switch from the fuse box.

Warranty

The 2-year warranty starts from the day of delivery and includes parts and labour for the first year. The remaining period covers replacement parts only. This warranty is conditional on planned maintenance being undertaken.

- Technical Support

Contact Details

For more information on how to operate your Home Air Circulating Fan please call technical support on: **03448 560594**

3. YOUR APARTMENT LAMPS

3.1 [Product Description](#)

The lighting installed in your apartment comprises of MK ceiling pendant illumination light fittings in the Living Room and bedrooms; an Orlight ORLL30LED light fitting & an Orlight ORL1377H Mirror fixture in the Bathrooms; and an Orlight LEO28WH light fitting in the Kitchen.

Light Fixture Components

MK Pendant Product (Living Room / Bedrooms / Corridor)



MK 1189 WHI Light Fitting



BELL 04921 Spiral Lamp

Orlight Product (Bathrooms / Toilets)



ORLL30LED Light Fitting



ORL1377H Mirror Light

Orlight Product (Kitchen)



Orlight LEO28WH

3.2 [How to Change Your Lamp](#)

Note: Safety First

- Please use the correct PPE (Personal protective equipment):
 - Safety glasses
 - Appropriate hot work gloves
- Please use a safe raised working platform and do not stand, kneel or ever use the HIU cupboards shelf as a working platform.

Step 1. Turn Off Power

Make sure the power to the lights within your apartment are turned off. The safest way to ensure the power is off before you change a light bulb is to isolate or knock the power off at the source. Turn off isolator switch located in the fuse box prior to commencing work, by flicking the switch, on the breaker/fuse box, within the heating cupboard to its off position (Please see figure 3.1).

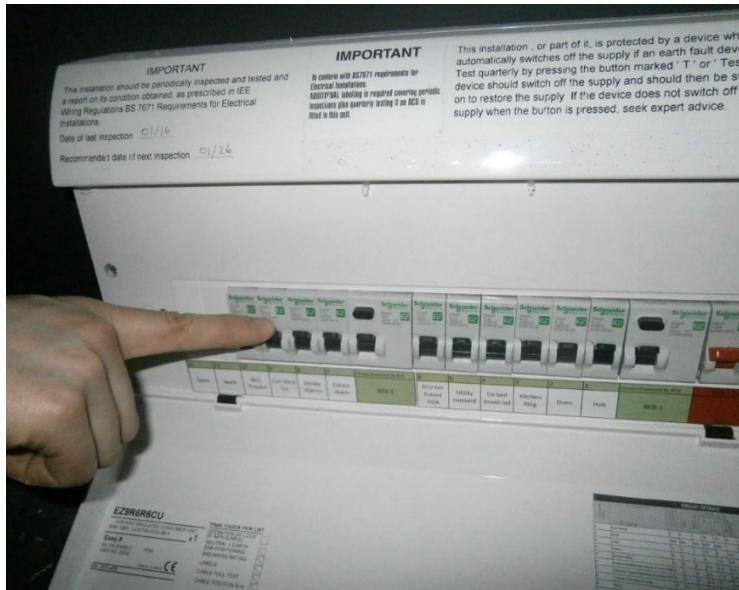

Fuse box (Figure 3.1)

Step 2. Let It Cool Down

Allow enough time for the lamp to cool down if necessary, before attempting to touch and separate the housing or to change the bulb.



Step 3. Separate the Light Housings (For Bathroom and Kitchen fittings)

The Kitchen fitting (LEO28WH) is easy to tear down by removing the cover. In order to remove the cover, we need to apply some pressure on the plastic cover inward within the mounting (releasing the holding clips), then we need to slide the cover towards one side until the edge is out of the fitting and we can grab the whole cover out by sliding it out of the fitting sides.

Step 4. Remove the Lamp

- MK 1189 - In your Living room, Bedrooms and Corridors your light system comprises Bell B22 bulbs. To remove them, you have to hold the fitting while pushing up the bulb against it (to compress the loaded spring) and turn anticlockwise to release the bulb pins from the fitting.
- ORLL30LED – The Lamp in the Bathrooms is a standalone system. If replacement is needed, a new ORLL30LED must be fitted.
- ORL1377H – The Bathroom mirror light can be replaced by a T5 24W lamp.
- LEO28WH – Take out the lamp by holding it by the centre point of the bulb unit (not the bulb itself) and pulling it out of the fitting to free the pins.

Step 5. Replace Lamp

- MK 1189 - To replace the lamp in the living Room, Bedrooms and corridors, you need to push the new lamp against the fitting (to compress the loaded spring) and turn clockwise until the pins are in their locked position.
- ORLL30LED – The Lamp in the Bathrooms is a standalone system. If replacement is needed, a new ORLL30LED must be fitted.
- ORL1377H – The Bathroom mirror light can be replaced by a T5 24W lamp.
- LEO28WH - Replace the lamp with a 2D 28W low energy lamp type by pushing it into the socket (holding it by the centre point of the bulb). Then we need to slide the cover back in the opposite way we took it out.

Step 6. Turn on Power

Now that the new lamp has been fitted and you feel as though you have safely carried out the replacement procedure, it is now time to turn back on the power. To recirculate power to the apartment lights, flick the switch, on the breaker/fuse box, within the Utility cupboard to its on position.

Step 7. Disposal

After fitting the new lamp, it is now necessary to dispose of the old lamp. This needs to be done in a safe manner, as the old bulbs glass may be fragile and very sharp. One approach to this is to wrap the old lamp in the packaging of the newly fitted lamp and dispose it in the nearest Lamp recycling bin or lamp disposal service.

3.3 Lamp Safety

Safety is critical when working with faults related to electrical or wiring issues. Remember to always check the following:

1. The wattage on the old used bulb and replace it with a new lamp of the same wattage.
2. Keep your fingers away from live electrical wires and do not put your fingers in the exposed light socket.
3. In the interest of health and safety, dispose of the light lamp well out of the reach of children.

4. DOOR ENTRY PHONE

Product Description

The door phone control system within your apartment is a Comelit Icona interface (6602W). The video door phone is designed to have a minimal extra-slim style, with a 4,3" touch screen display with gesture recognition.

4.1 [COMELIT ICONA DOOR ENTRY PHONE](#)



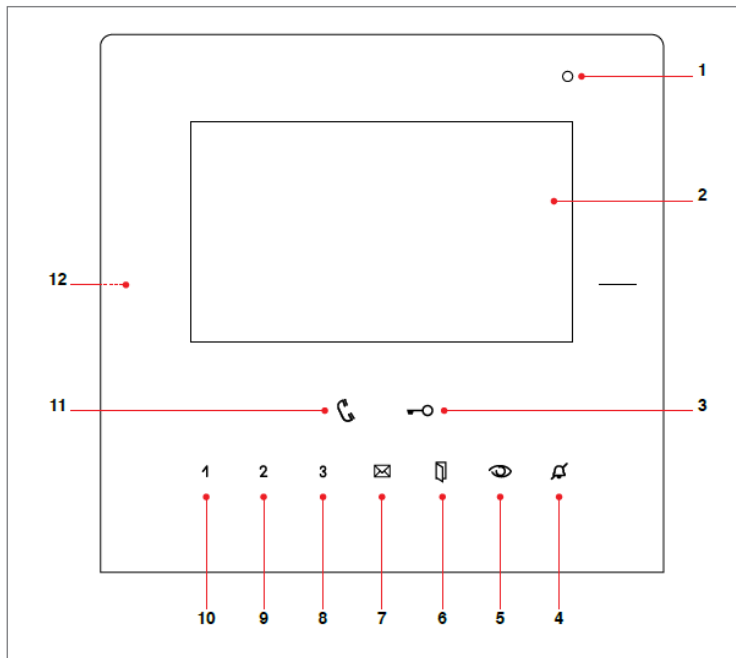

MONITOR DESCRIPTION



1. Microphone
2. 4.3" touch screen
3. Door lock key [programmable]
4. Privacy / Doctor key [programmable]
5. Self-ignition key [programmable]
6. Open doors key
7. Video memory key
8. Key "3" [programmable]
9. Key "2" [programmable]
10. Key "1" [programmable]
11. Audio key
12. Micro SD card port

FUNCTION KEYS

 **Audio key:** activates or deactivates conversation with the external unit.

 **Door lock key:** opens the corresponding door lock.
[PROGRAMMABLE] LOCK RELEASE / ACTUATORS

1 Programmable key 1:
[PROGRAMMABLE] INTERCOM / SELF-IGNITION / LOCK-RELEASE / CALL PRIORITY 1-4 / ACTUATORS / ACTIVATE OUTPUT
DEFAULT = DEACTIVATED

2 Programmable key 2:
[PROGRAMMABLE] INTERCOM / SELF-IGNITION / LOCK-RELEASE / CALL PRIORITY 1-4 / ACTUATORS / ACTIVATE OUTPUT
DEFAULT = DEACTIVATED

3 Programmable key 3:
[PROGRAMMABLE] INTERCOM / SELF-IGNITION / LOCK-RELEASE / CALL PRIORITY 1-4 / ACTUATORS / ACTIVATE OUTPUT



- In ADDITION to the programmable functions for keys 1 - 2 - 3 it is possible to assign one SCENARIO that will be activated at the same time as the associated function is activated by pressing the corresponding key (1 - 2 - 3).

 **Video memory key:**
PRESSED allows access to the messages section.
LIT STEADILY video memory or absent message active.
FLASHING new message waiting.

 **Open doors key:**
LIT STEADILY signals the opening of one or more of the doors listed in the directory
PRESSED allows access to the open doors section.

 **Self ignition key:** switches on the monitor and displays video from an external unit.
[PROGRAMMABLE]
INTERCOM / SELF-IGNITION / LOCK-RELEASE / CALL PRIORITY 1-4 / ACTUATORS / ACTIVATE OUTPUT

 **Privacy / Doctor function key [PROGRAMMABLE]**

- The PRIVACY function disables calls from the external unit and from the switchboard.

- The DOCTOR function enables automatic activation of the lock-release in response to a call from the external unit.

- The PRIVACY + DOCTOR function, in addition to disabling the door-entry phone ringtone in the same way as the Privacy function, also enables automatic activation of the lock-release in response to a call from the external unit.

ICONA ViP MENU

The icons in the Icona ViP menu vary according to the type of system installed and the functions available.

To navigate the menu, simply use your finger to touch the icon corresponding to the desired function.

- ▶ Touch the display to access the main menu.

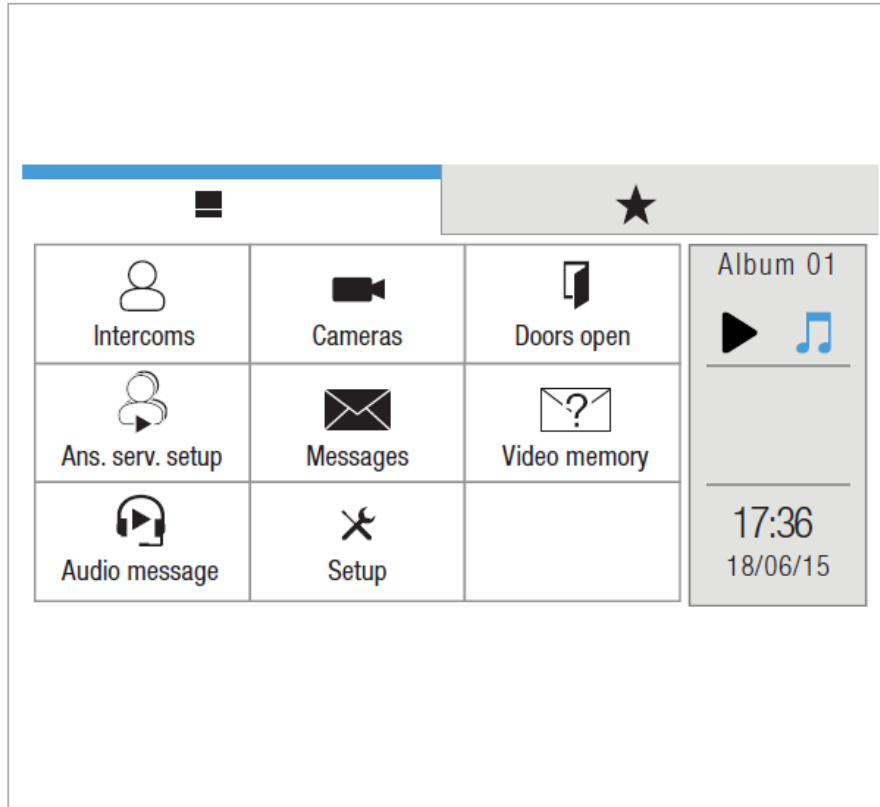

- ▶ Navigate through the available screens by swiping with your finger to the left or right.

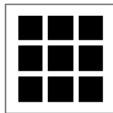

- ▶ Press the icon to immediately return to the main menu.



- ▶ Press the icon to return to the previous screen.

FAVOURITES BAR, FAVOURITES PAGE AND ADVANCED INFO

Hold pressed one of the icons in the main menu to open the corresponding favourites bar / favourites page / advanced info panel.

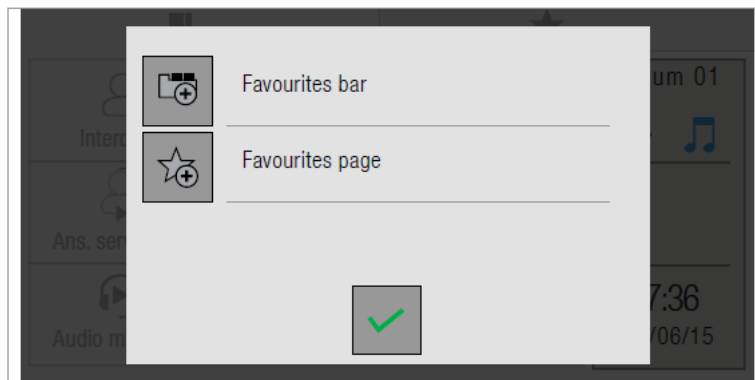
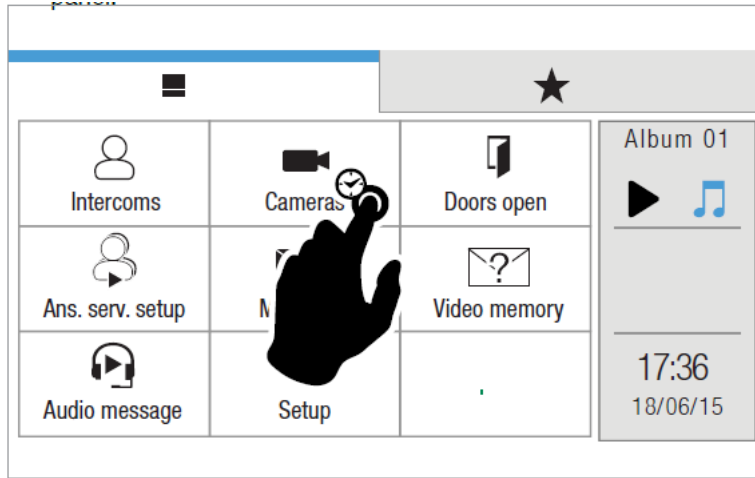

FAVOURITES



- ▶ Select the Favourites bar to create a link to the selected function in the favourites bar.

» *The link allows you to display the corresponding page simply by pressing the icon in the top bar from any screen page.*



- You can create a link to a function or to a room.
- **CAUTION!** You cannot create a link to a single element!
- Maximum number of links in the favourites bar = 4

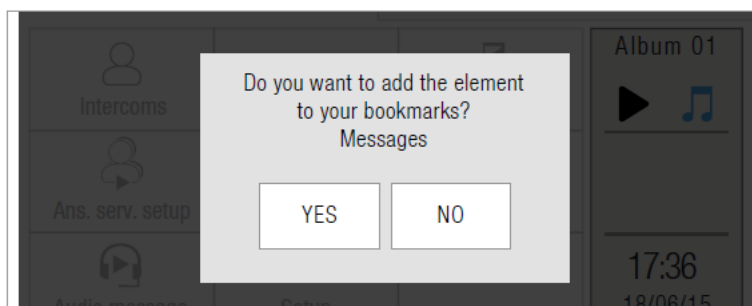



- ▶ Select the Favourites page icon to create a link to the selected function in the favourites page.

- » *The link allows you to display the relative page simply by pressing the icon in the favourites page.*
- » Maximum number of links in Favourites page = 18
If there are more than 9 links, they will be displayed over 2 screens.
- ▶ Navigate through the available screens by swiping with your finger to the left or right

4.2 DOOR ENTRY MONITOR FUNCTIONS

The door entry phone main menu will comprise of different functions (Please see the picture below). These functions will be explained in the next pages.

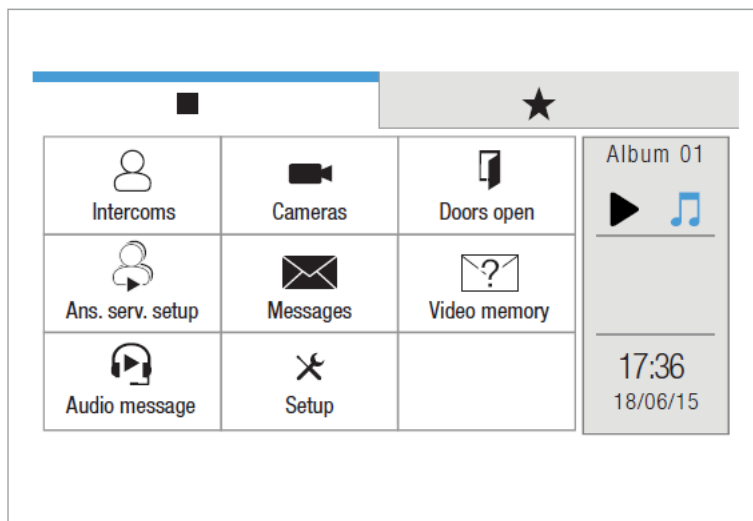

- If enabled (via ViP Manager), the ACTUATORS DIRECTORY will be displayed with the actuators icon.

- INTERCOMS

This function allows you to call up a directory of addresses (see "Door entry monitors - Intercoms directory" on page 17).



► Press the icon to access the function, then select from the directory the device to which the call is to be diverted via intercom call.

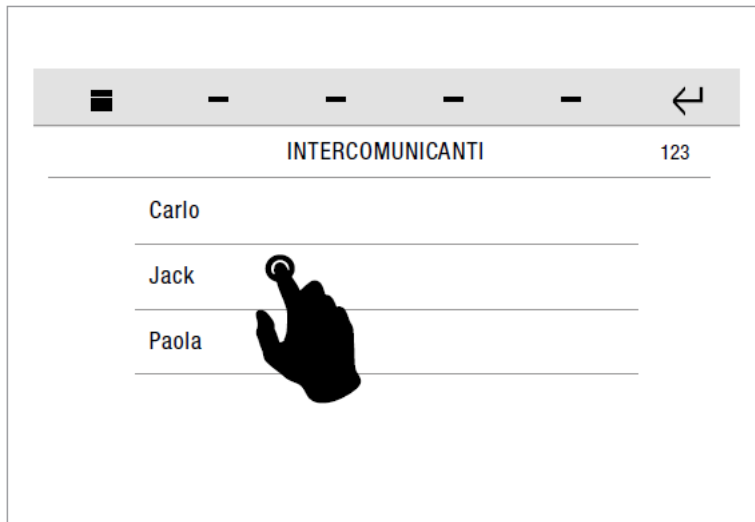

123 ► Press the icon to enter the ViP address to call.

- CAMERAS

This function allows you to interrogate a directory of cameras (see "Door entry monitors - Cameras directory" on page 16) to start live streaming.

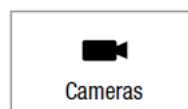

► Press the icon to access the function, then select from the directory the camera to be interrogated.

- OPEN DOORS

This function allows you to interrogate a directory of doors (see "Door entry monitors- Doors directory" on page 18) to check their status (open/closed).



▶ Press the icon to access the function, then select from the directory the door to be interrogated in order to start viewing the cameras associated with the door.

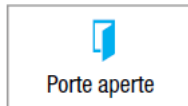

» *The icon changes to indicate that the door is open.*

- ANSWERING SERVICE SETUP

This function allows you to manage the parameters for the device's video memory function



▶ Press the icon to access the dedicated sub-menu.



▶ Tick the VIDEO MEMORY box to activate the corresponding function.



» *The icon changes status.*

» *The icon  on the soft touch key lights up.*



► Tick the AUDIO MESSAGE box to activate the voice message automatic playback function.

- Short press RECORD MESSAGE to start recording the AUDIO MESSAGE.
- Short press LISTEN RECORDED MESSAGE to play the recorded AUDIO MESSAGE.

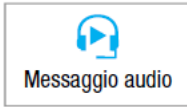

» The icon changes status.

» The icon  on the soft touch key lights up.

• MESSAGES

This function allows you to manage the ViP messaging system of the device.





► Press the icon to access the dedicated sub-menu.

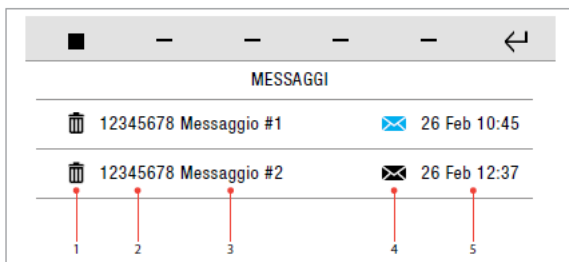

► Press the **COMMON MESSAGES** icon to access the ViP message sub-menu.



1. Delete message icon
2. Sender ViP address
3. Message title
4. New message  / previously read message icon 
5. Date message received

► Short press on the message title to open the message.

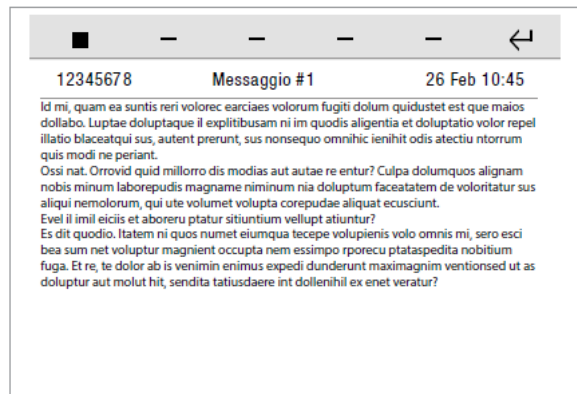

► Press the **VIDEO MESSAGES** icon to access the video memory sub-menu.

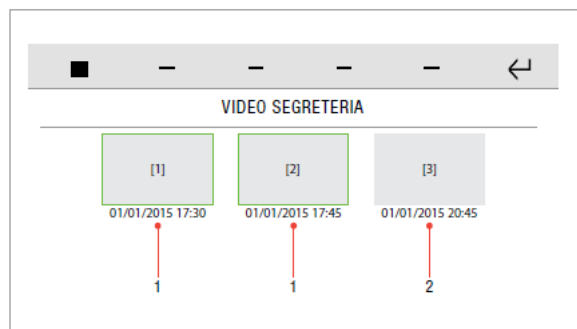

1. Previously viewed video recording
2. New video recording resolution



- [1] [2] [3] are previews of the video recordings recorded in the video memory.
- Each video is labelled with the date and time it was recorded.

- Short press on the recording preview to start playback.
- Long press (and confirm) to delete the video recording.

- **CALL DIVERT**

This function allows you enable call diversion to another ViP device (see "Door entry monitors - Call divert" on page 18) if there is no response from the original device or if it is in use.



▶ Press the icon to activate the function.



» *The icon changes status (call divert activated).*

- **VIDEO MEMORY**

This function allows you to enable the video memory on the device. (See "DOOR ENTRY MONITORS - Answering service setup" on page 5).

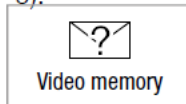

▶ Press the icon to activate the function.



» *The icon will change status (video memory activated).*

- **AUDIO MESSAGE**

The function allows you to enable audio message playback on the device on receipt of an incoming call. (See "DOOR ENTRY MONITORS - Answering service setup" on page 5).

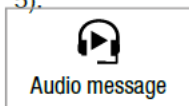

▶ Press the icon to activate the function.

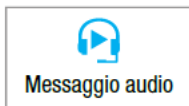

» *The icon changes status (audio message activated).*

- MULTIPLE ADDRESSES

The function allows you to configure the device to manage multiple addresses, thereby permitting the reception of calls directed to other VIP devices.

(See "Door entry monitors - Configure multiple addresses" on page 20).

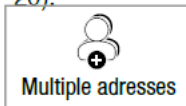

► Press the icon to access the dedicated sub-menu.

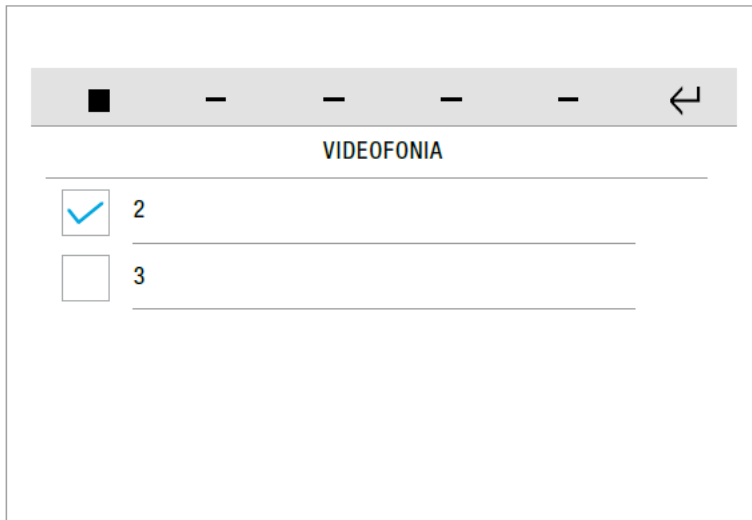

► Tick the desired device to activate the function in combination with its previously configured address. (See "Door entry monitors - Configure multiple addresses" on page 20).



► If at least one multiple address is activated, the icon will change status.

4.3 AUDIO BROADCAST

The audio broadcast function allows you to play music and audio files in the various rooms connected to the home automation manager.

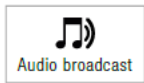

Audio broadcast

► Press the icon to access the function.

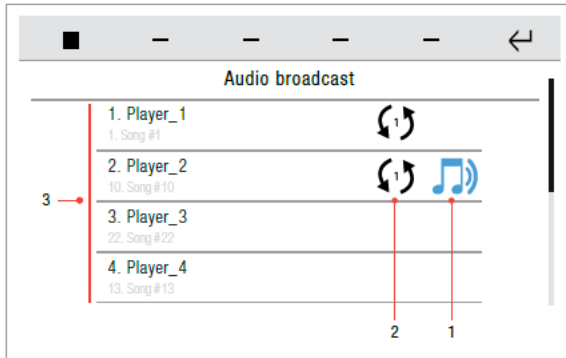

1. Player status icon*
2. Sync icon: number shown (e.g. 1) = master player
3. List of available players

* PLAYER STATUS TABLE	
	Player OFF
	Player ON but not playing
	Player ON and playing

► Long press on a player to open the advanced info panel.

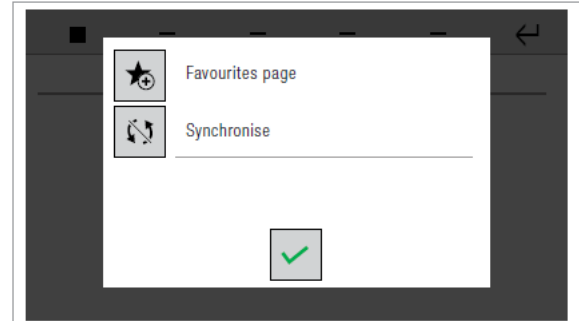

► Press the icon to add the player to the favourites page.



► Press the icon to synchronise the player with another player.



• Press the icon until the id of the desired synchronisation master player is shown, then confirm.



Player
NOT
SYNCHRONISED



Player SYNCHRONISED
with the master player
indicated by the number N

AUDIO BROADCAST - Player screen

► Short press on a player to open the play panel.

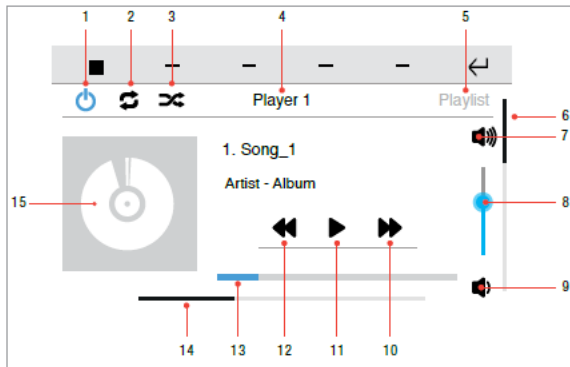

1. ON - / OFF icon -
2. Repeat icon (see table R)
3. Shuffle icon (see table)
4. Selected player
5. Playlist icon
6. Scroll to view all the available players
7. Volume + icon
8. Volume level indicator
9. Volume - icon
10. Next track icon
11. Play icon
12. Previous track icon
13. Track progress bar
14. Scroll to view (Player - Playlist - Library)
15. Album artwork

► Press the icon to activate the REPEAT function (each touch activates a *different status** of the function).

R TABLE - REPEAT ICON STATUS*	
	Repeat IDLE (no repeat)
	Repeat playlist (repeats current playlist)
	Repeat song (repeats an individual song)

► Press the icon to activate the SHUFFLE function (each touch activates a *different status** of the function).

S TABLE - SHUFFLE ICON STATUS	
	Standard order (as per playlist)
	Random shuffle by song
	Random shuffle by album

► Press the play icon to start playback.

» *The icon changes status.*
► Press the pause icon to pause playback.

AUDIO BROADCAST - Playlist screen

► Scroll to the left to display the PLAYLIST page

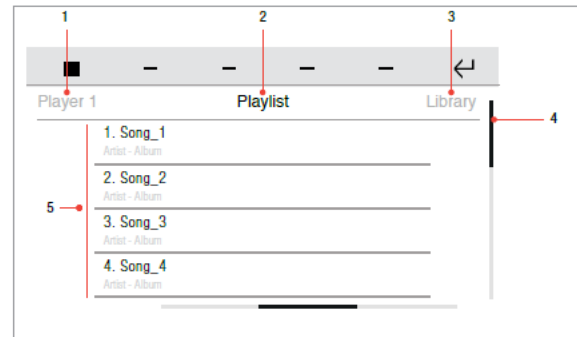

1. Player page icon
 2. Selected playlist
 3. Library page icon
 4. Scroll to view all the available songs
 5. Songs contained in the playlist
- Short press on a song to start playback.

» *The active playback icon will appear next to the song being played.*

AUDIO BROADCAST - Library screen

► Scroll to the left to display the LIBRARY page

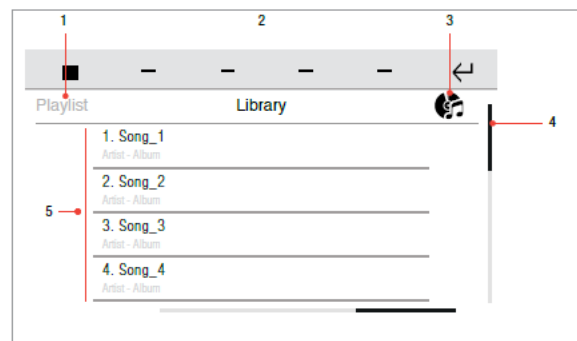

1. Playlist page icon
2. Library page (current page)
3. Playlist / album mode icon
4. Scroll to view all the available songs
5. Songs contained in the library

	PLAYLIST mode the library displays all the playlists available
	ALBUM mode the library displays all the albums available

► Press the icon to toggle between PLAYLIST and ALBUM library mode.

4.4 SETUP MENU



► Press the icon to access the setup menu.

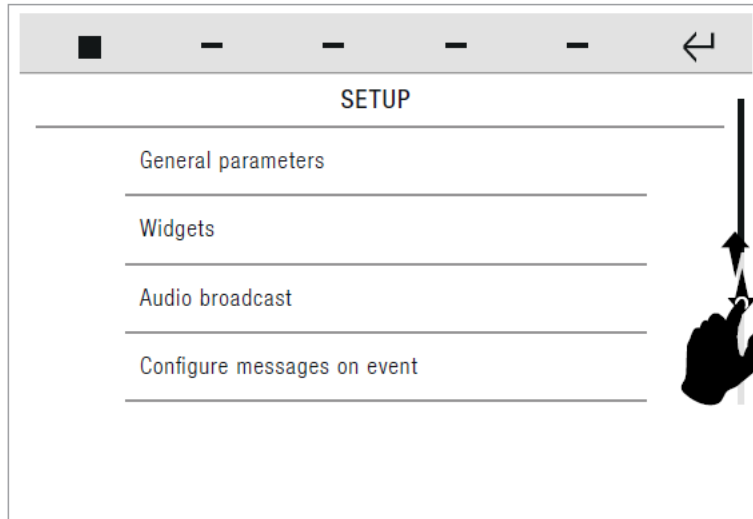

- Swipe your finger up or down to view all the available menu options.

- To access the desired sub-menu, press the corresponding icon.

- » *The available options are: General parameters / Widgets / Audio broadcast / Configure event messages / Advanced.*

SETUP - General parameters

SETUP-General parameters

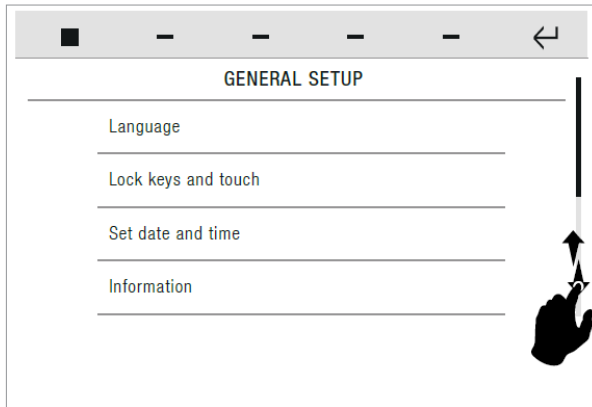

- ▶ Swipe your finger up or down to view all the available menu options.
- ▶ To access the desired sub-menu, press the corresponding icon.
- » *The available options are: Language / Keypad lock and touch screen / Set date and time / Information / Volume control / Set ringtones / Soft touch keys.*

General parameters-Language

SETUP-General parameters-Language

You can change the interface language.

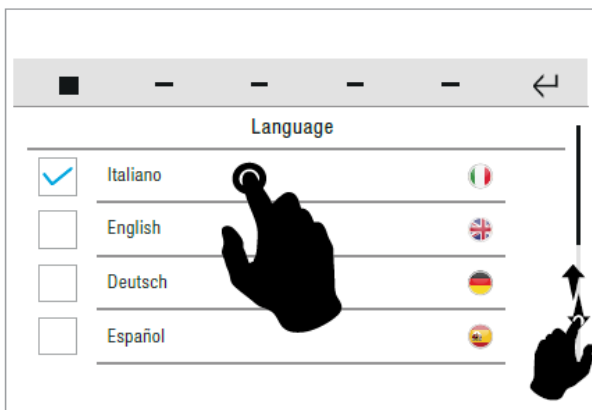

- ▶ Select the desired language by pressing the relative icon, then confirm the selection.

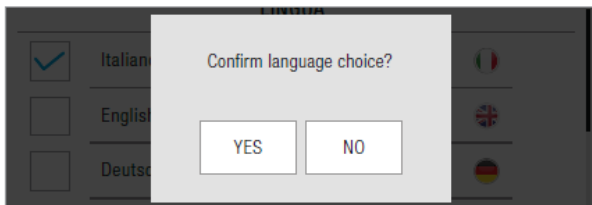

- If the system includes a Vedo control panel, the language is automatically set to that used by the control panel itself, regardless of the language selected.

General parameters-Keypad lock and touch screen

SETUP-General parameters-Keypad lock and touch screen

The function can be used to lock the device touch screen for 60 seconds, for cleaning purposes.

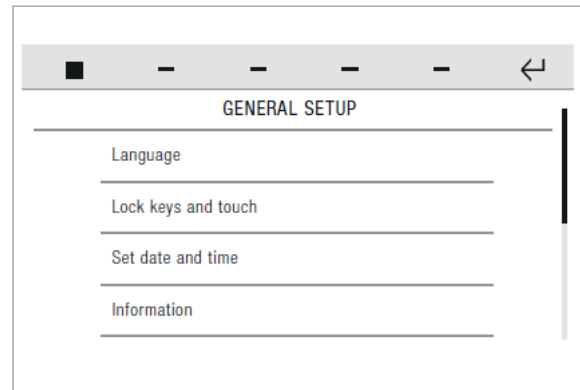

- ▶ Confirm the operation.
- » *After 60 seconds, the device is unlocked automatically.*

General parameters-Set date and time

SETUP-General parameters-Set date and time

This function allows you to set the time and date of the device.

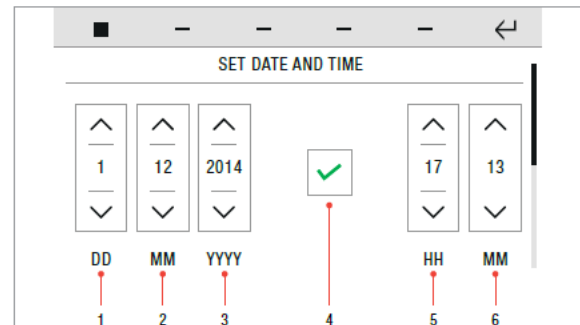

1. Day setting
2. Month setting
3. Year setting
4. Confirm icon
5. Hours setting
6. Minutes setting

- ✓ If the system includes an alarm control panel, then setting the time becomes a function of the alarm system; this requires the alarm password and any changes made will be applied to the control panel.



- ▶ Set the desired values for day / month / year / hours / minutes.



- ▶ Save the configuration.

General parameters-Information

SETUP-General parameters-Information

This menu provides technical information about the device (e.g. type of device, versions, addresses, etc.).

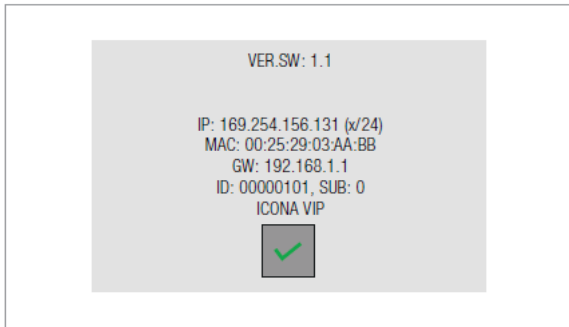

▶ Press the icon to exit the screen.

General parameters-Volume control

SETUP-General parameters-Volume control

The menu allows you to manage and control the audio volumes associated with the various functions of the device.

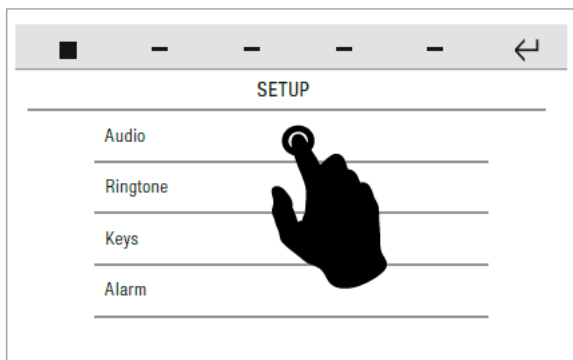

▶ Select the desired function.

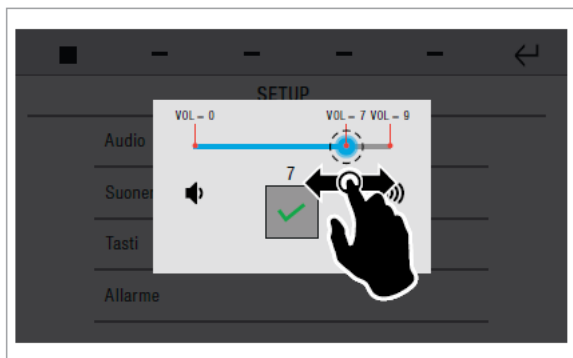

▶ Press and drag the cursor to adjust the volume.



▶ Save the configuration.

General parameters-Set ringtones

SETUP-General parameters-Set ringtones

The menu allows you to manage the ringtones and control the audio volumes associated with the call functions of the device.

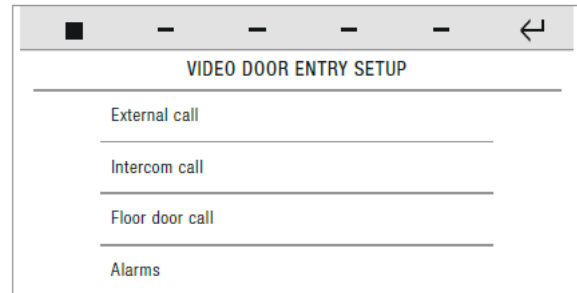

▶ Select the desired function.

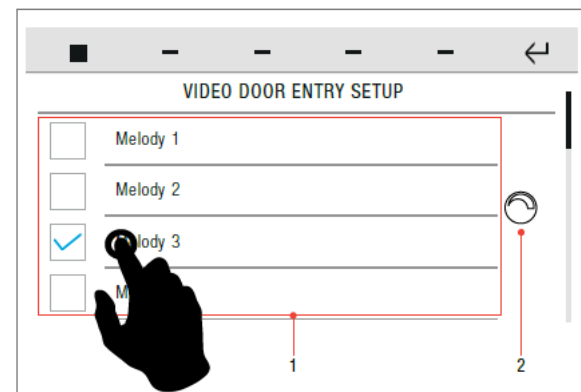

▶ Press the name of the melody hear a preview.

▶ Select/deselect the desired option by pressing the corresponding box.



▶ Press the icon to open the volume control panel.



▶ Press and drag the cursor to adjust the volume (as described in "General parameters-Volume control" on page 10)



▶ Save the configuration.

General parameters-Soft touch keys

SETUP menu-General parameters-Soft touch keys

This function allows you to decide how to activate the device's soft touch keys (short press/swipe).

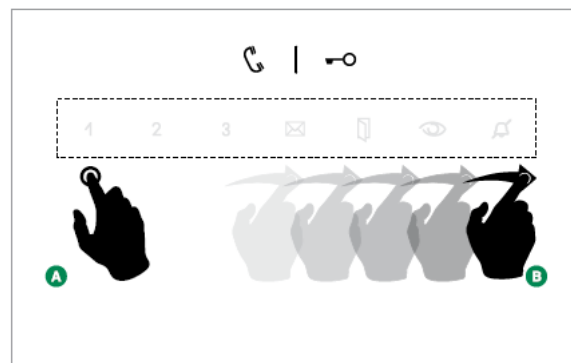
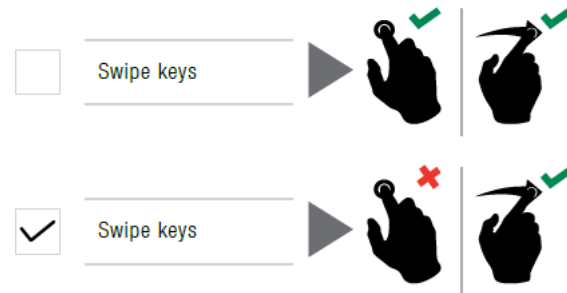

SETUP-Widgets

SETUP-Widgets

The menu allows you to select which widgets are to be shown on the HOME page.

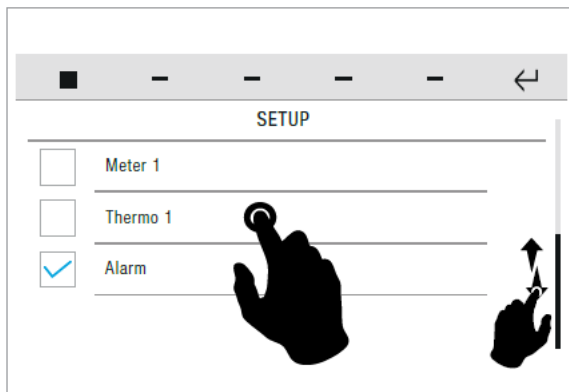

► Swipe your finger up or down to view all the available menu options.

► Select/deselect the desired option by pressing the corresponding box.

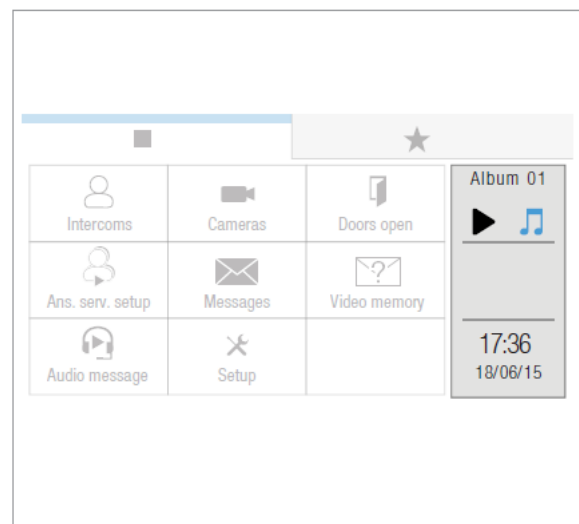
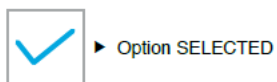
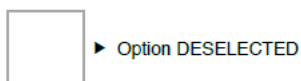

• MAX number of widgets that can be selected simultaneously = 2

SETUP - Audio broadcast

From this menu you can manage the operating parameters of the audio broadcast function.



- For configuration of the media server, refer to the technical documentation available online at the address http://wiki.slimdevices.com/index.php/Logitech_Media_Server
- For configuration of the player, refer to the manual art 20004500 / 20004501 / 20004502

SETUP

Enable

Address IP

Port

Username



- ▶ Tick the ENABLE box to activate the audio broadcast function.

» The parameters that can be configured are:
IP address / Port / Username / Password.

- ▶ Press the desired parameter to open the dedicated menu.

IP Address

SETUP-Audio broadcast-IP address



- ▶ Enter the IP address of the desired audio broadcast server, then confirm.

192.168.1.226

1	2	3
4	5	6
7	8	9
.	0	✓



- DEFAULT VALUE: 192.168.1.226

Port

SETUP-Audio broadcast-Port



- ▶ Enter the port of the desired audio broadcast server, then confirm.

9000

1	2	3
4	5	6
7	8	9
←	0	✓



- DEFAULT VALUE: 9000

Username

SETUP-Audio broadcast-Username



- ▶ Enter the desired username, then confirm.

admin

q	w	e	r	t	y	u	i	o	p
a	s	d	f	g	h	j	k	l	
↑ Aa	z	x	c	v	b	n	m	←	
123								✓	

Password

SETUP-Audio broadcast-Password



- ▶ Enter the password associated with the username and confirm.

q	w	e	r	t	y	u	i	o	p
a	s	d	f	g	h	j	k	l	
↑ Aa	z	x	c	v	b	n	m	←	
123								✓	

SETUP - Configure event messages

From this menu you can configure the email addresses of the recipients of automatic messages sent on activation of a previously configured input.



• Maximum of 4 recipients!

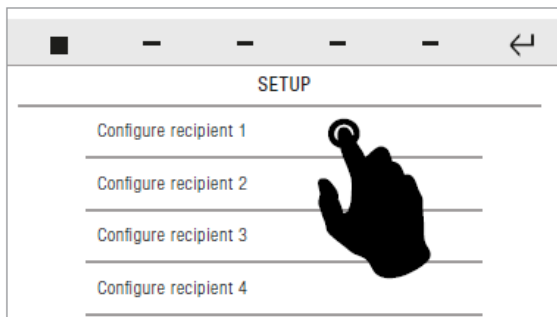

► Press on the desired recipient to enter or edit the address.

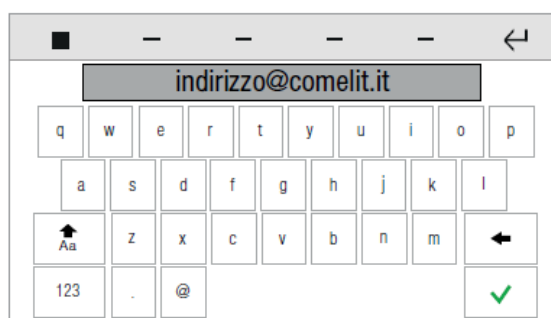

► Enter the address and confirm.

SETUP - Advanced

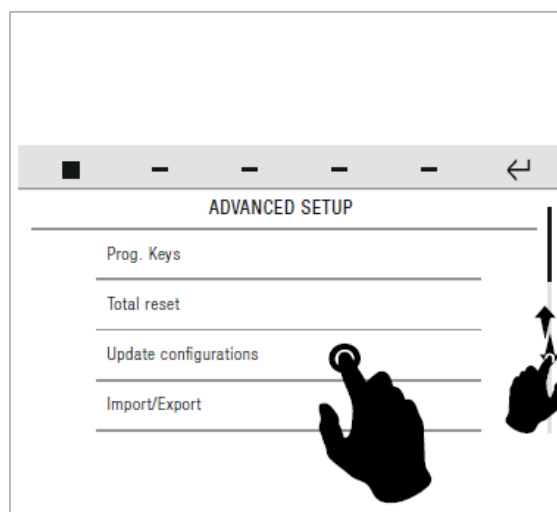

► Swipe your finger up or down to view all the available menu options.

► To access the desired sub-menu, press the corresponding icon.

» The available options are: Programming keys / Total reset / Import/Export / Door entry monitors.

Programming keys

SETUP-ADVANCED-Programming keys

From this menu you can assign one of the available functions to each of the PROGRAMMABLE KEYS.

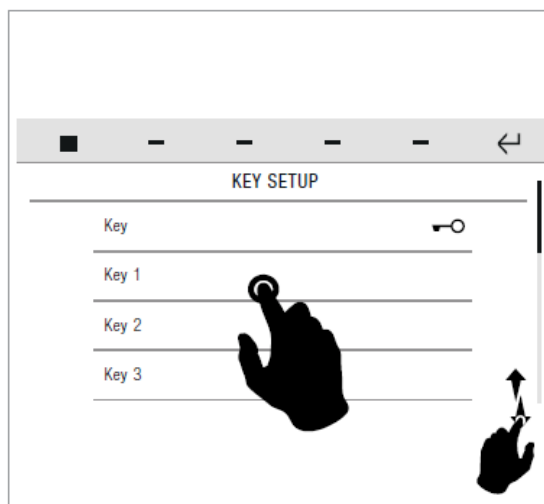

► Swipe your finger up or down to view all the available menu options.

► To access the desired sub-menu, press the corresponding icon.



• For a list of the available functions that can be associated, refer to "FUNCTION KEYS" on page 3.

Total reset

SETUP-ADVANCED-Total reset

This function deletes all user, door entry monitor, home automation and alarm system settings, plus calibration settings, restoring the default settings of the product.

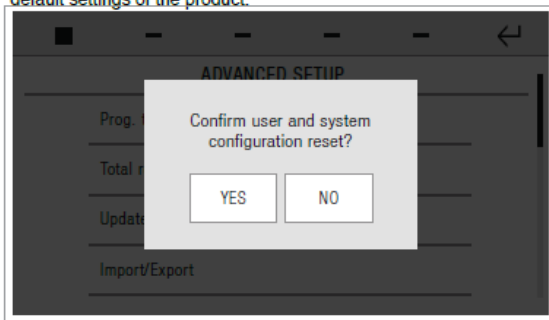

- Confirm the operation.

Import/export

SETUP-ADVANCED-Import/Export

The function can be used to save or load all user, home automation and alarm system configurations.



- An SD card with sufficient memory to save the backup file is required. Otherwise the system will display an error message.

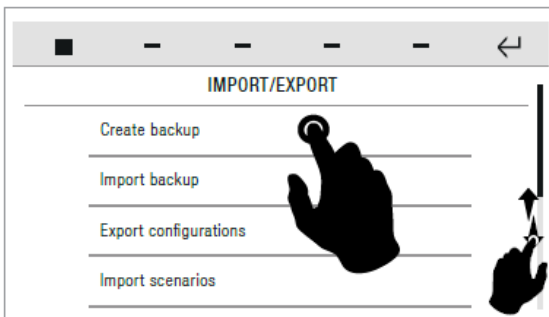

- To access the desired functions, press the corresponding icon.

» The available options are: *Create backup / Import backup*

Create backup

SETUP-ADVANCED-Import/Export-Create backup

This function allows you to create a complete system backup and to save it on an SD card.

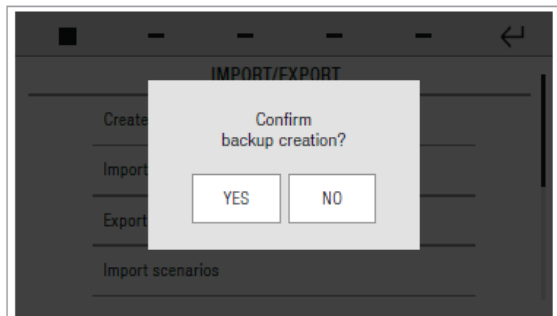

Import backup

SETUP-ADVANCED-Import/Export-Import backup

This function allows you to import a complete system backup from an SD card.

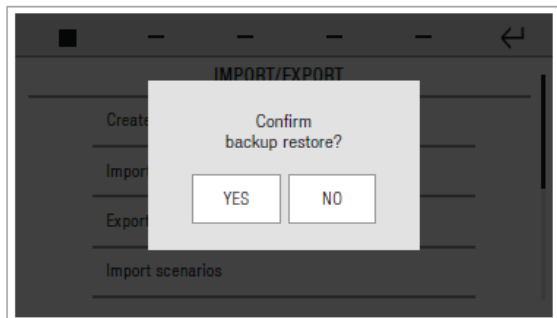

5. SHOWER UNIT ALTO ECOTHERM (A5636)



The shower unit installed in your apartment is an Alto Ecotherm A5636.

It's comprised of a shower rail for the shower head and a bath mixer with controls and thermostatic valve embedded.

5.1 Operation

- Step 1. Turn the Flow control handle (right handle) anti-clockwise to increase the flow of water to the shower rose.
- Step 2. To divert the water to the handset pull the button while the water flow has been increased.
- Step 3. Turn the Temperature control handle (left handle) to increase/decrease the temperature. Clockwise for Cold Water, anti-clockwise for warmer water.
- Step 4. Push down on the Override button (in the temperature handle) and turn the handle anti-clockwise to override the set temperature
- Step 5. Return the control handle to the upright position with the button on top to turn off the flow of water.
- Step 6. To change the set temperature, please see section next section on Temperature Setting.

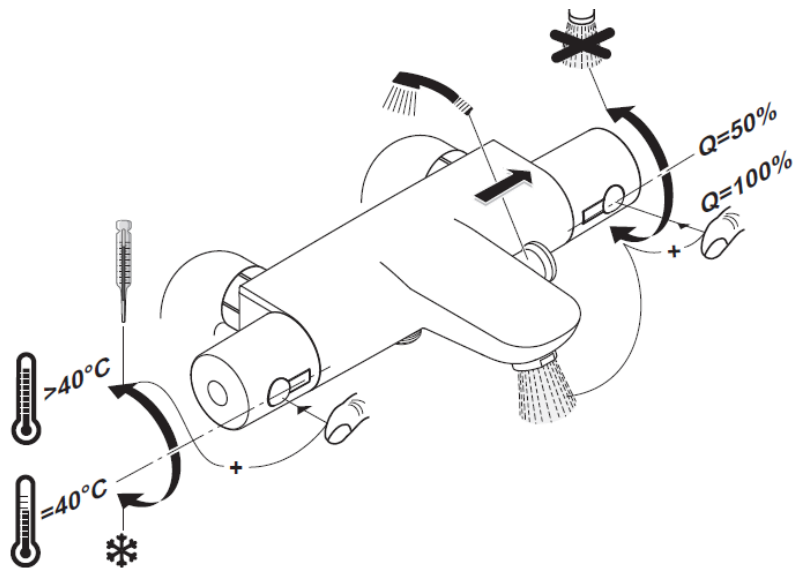

5.2 Temperature Setting

Step 1. Removing the handle/cover – Take the screw cover on the side of the handle/cover, unscrew the Phillips grub screw, pull off the handle/cover (1-3)

Step 2. Rotate the exposed thermostatic handle (clockwise for cold, and anti-clockwise for hot) until the maximum desired showering temperature is set (38°C - suggested maximum “pre-set” temperature) (4)

Step 3. Pull off the stop ring to free the handle from the body (5).

Step 4. Pull out the handle from the body and adjust the location marks to be aligned (6).

Step 5. Push the handle onto the body again and place back the stop ring.

Step 6. Place back the Handle cover and screw back the Phillips grub screw.

Step 7. The thermostat is now set to its new temperature and can only be increased or decreased by repeating this process.

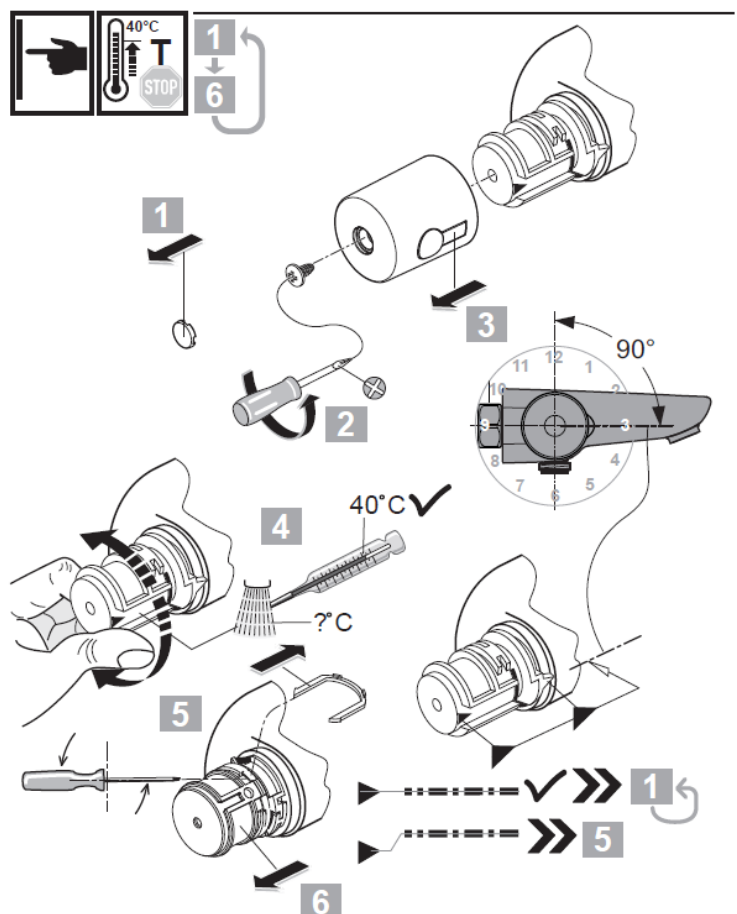

5.3 Cleaning

Taking Care of Your Shower Valve & Riser

We recommend cleaning the valve with a soft damp cloth.
We strongly advise against the use of ALL cleaning products.

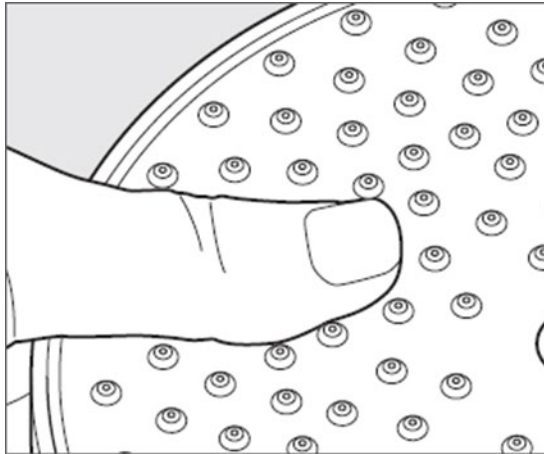

Shower Rose & Handset

Your shower rose and handset has rub clean nozzles for easy cleaning. Rub your fingers across the rubber nozzles to remove any scale or debris. If you live in a hard water area you might have to repeat this procedure regularly.

5.4 Maintenance

NOTE: Before carrying out any maintenance please remember to turn OFF all mains water and turn ON the isolating valves.

Thermostatic Cartridges

The concealed thermostatic valve should give trouble free service, but in the event of failure, servicing is straight forward.

Procedure on How to Remove the Thermostatic Cartridge.

- Step 1. Remove the handle/cover - see temperature setting.
- Step 2. Pull off the stop ring.
- Step 3. Remove completely the exposed handle.
- Step 4. Using a spanner undo and remove the valve out of the body.
- Step 5. Wash the cartridge with clean running water and make sure that any trapped debris has been removed.
- Step 6. Dry and lightly grease the seals (only use silicone grease) and replace the cartridge. Tighten the cartridge properly to the body.
- Step 7. Place back the exposed handle and the stop ring, make sure are properly aligned (Please see Temperature setting).
- Step 8. Push the handle cover and screw back the cover screw. Put back the screw cover.

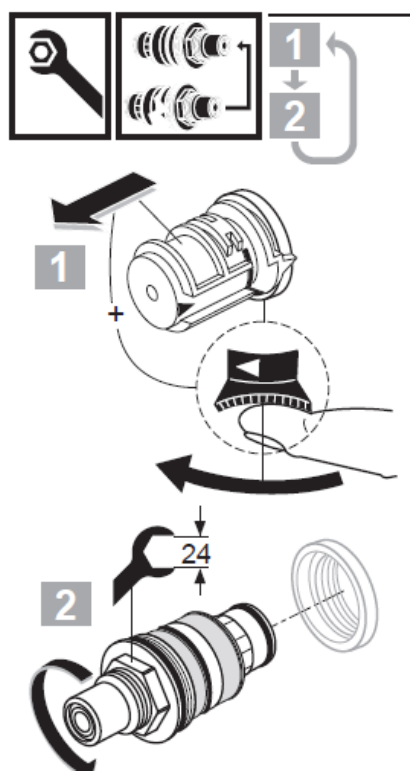

Filters

Turn off water supply to the valve and remove from the wall. Using a wrench key undo the retaining nut within each of the inlets. Wash the filters with clean running water and replace.

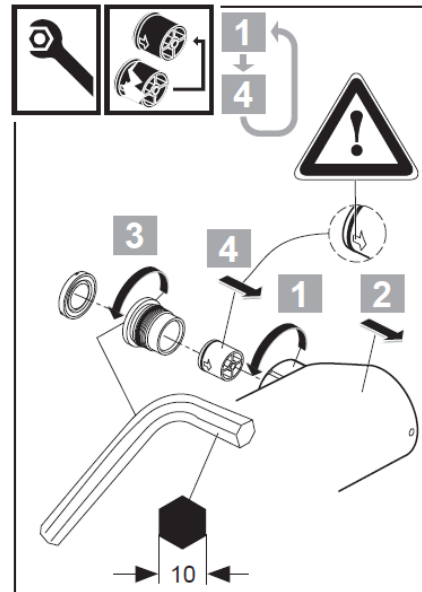

Flow Control Cartridge

The Flow Control Cartridge uses ceramic discs which normally last indefinitely unless debris manages to get between them. Wash the cartridge with clean running water, dry and lightly grease the seal.

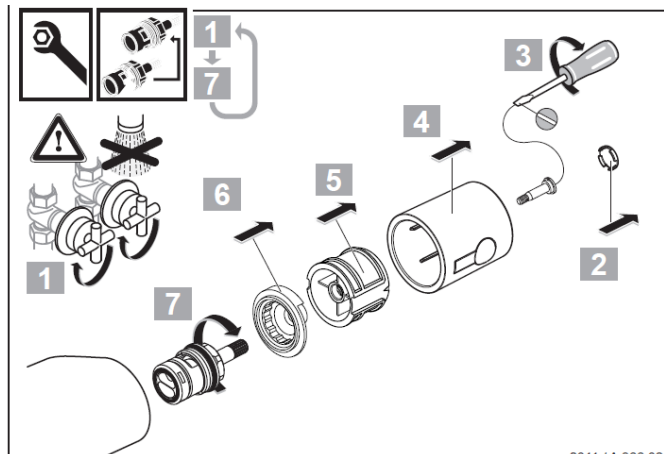

0311 / A 866 321

Trouble Shooting

SYMPTOM	SOLUTION
After installation the shower runs HOT or COLD and will not mix.	Hot and cold supplies are plumbed the wrong way round.
Shower will not run hot enough when first installed.	Maximum temperature needs adjusting, see 'temperature setting'.
Cold water tracking through the valve into the hot water system.	Check and clean the filters.
Very low flow or no flow (gravity).	Check hot and cold feeds (the valve will shut down if either the hot or cold supply fails).

6. RADIATORS & TOWEL RAD

Your apartment is equipped with high performance compact radiators, and Stylish tubular design towel radiators for the bathrooms.



All the radiators in the apartment, except the ones in the same room than the thermostat (Viewsmart), are equipped with Drayton TRV4 Thermostatic Radiator valves, allowing the easy control of the temperature in the room. The TRV can be set up from 1 to 5, allowing an extra set point Max after 5.



7. FAQ

7.1 [Operate your Heating](#)

7.2 [Home Air Circulation Fan](#)

- **What is MEV/MVHR and where is it located in my apartment?**

In your apartment is MVHR (Mechanical Ventilation and Heat Recovery). It's working automatically and nonstop and you don't have set anything. When the humidity of the internal air raises over 70%, MVHR is boosted itself.

MVHR is removing used humid air out of your apartment while it keeps the heat and use this heat to warm up the cold fresh external air blown inside.

Your MVHR is located in the Utility cupboard in your apartment on the wall.

- **Is my MEV/MVHR air – conditioning/heating?**

No, MEV and MVHR is not air-conditioning or heating. For more information, please go to page number 26.

- **Why my MEV/MVHR doesn't make any noise?**

MVHR is working nonstop 24hours 7days per week. Manufacturers are trying to design the system which produces as less noise as it is possible. MEV/MVHR is not supposed to do almost any noise.

- **Do I have to clean/change the filter of MEV/MVHR?**

Manufacturers recommend cleaning the filter every 6 month. For cleaning the filter, you can use a Hoover. For more information about Filter and its cleaning, please go to page number 28.